



Installation Data

Shower Stalls, Tub/showers

Fax-On-Demand # 1900

NOTICE: Please inspect the unit thoroughly before installation to make sure it has not been damaged during transportation.

If you have any questions please call LASCO Bathware's Technical Services Department at 800-877-2005.

IMPORTANT! Before installation begins:

- READ ALL INSTALLATION INSTRUCTIONS COMPLETELY. IMPROPER INSTALLATION WILL VOID THE WARRANTY.**
- Make sure that walls and floors meet fire safety requirements of local building code and/or FHA/HUD Minimum Property Standards.
- The wood blocks attached underneath the bottom of the bath fixture units are for storing and shipping. These blocks need not touch the sub-floor. It is common in the industry to set foundation materials underneath the bottoms of tub and shower units with casting plaster/plaster of paris.
NOTE: Finished alcove must have interior dimensions, shown on product technical data sheet rough-in diagrams, to properly install unit.

Pre Installation Requirements

- In remodeling, if necessary, add studs at each end to provide a vertical nailing surface for the side nailing flanges of bath fixture product.
- To avoid obstruction during installation make sure that supply lines, spout pipe and valve plumbing do not project into alcove.
- Shower stalls require a 6" (150mm) diameter floor opening for 2" (50mm) IPS drain fitting connection. [See Diagram 1]
- Tub/showers require a 6" x 12" (150mm x 305mm) floor opening for the 1½" (40mm) drain, waste and overflow (DWO) kit. [See Diagram 2]
NOTE: Be sure floor opening location matches bath fixture drain location.
- Use of casting plaster/plaster of paris (foundation material) is recommended in all commercial structures (i.e. hotels, motels, dormitories, health clubs, etc.).

Installation

If mounting fittings on tub or shower; from stable reference points (back wall studs, floor) measure the locations of spout and valves. Note measurements here:

Tub Filler: _____ Valve: _____

Shower Arm: _____ Valve: _____

(Mark dimensions only if shower arm is plumbed within bath fixture wall area.)

- Make sure framed-in alcove is of proper size per LASCO dimensions, square, and plumb; check floor for levelness.
- Place the unit in the alcove with the front skirt firmly on the floor. **The unit should be set level.** To check, use a level on top of both end walls and on top of dam. Shim if necessary. [See Diagram 3]
NOTE: Fasteners: To wood framing - 1" (25mm) galvanized roofing nails or 1" (25mm) pan head screws; to steel studs - drill flanges and studs with 3/16" (5mm) carbide bit and fasten with #10 x 1" (25mm) sheet metal screws with washers; to concrete/block walls use 1" (25mm) concrete nails with nailing tool or impactor. **NOTE:** To prevent cracking the unit, pre-drilling nailing flanges is required for acrylic units. For non-acrylic units, pre-drilling nailing flanges is strongly recommended.
- Bottom support materials: Casting plaster/plaster of paris (herein referred as foundation materials) are not necessary but its use is highly recommended for a firmer bottom support. When using foundation materials, the following applies:
In a bucket, mix foundation material. Place three or four mounds of plaster on the subfloor around but away from drain hole. The mounds should be placed high enough so that when the unit is set, it will cause the plaster to displace and spread.
- a. Spot fasten lower corners of vertical side nailing flanges
b. Fasten upper corners; work toward back from each front corner, fastening at each stud through horizontal flange, finishing at rear corner.
NOTE: Acrylic units require pre-drilling pilot holes for fasteners.
c. Complete fastening along vertical side flanges, 8" (200mm) on center. [See Diagram 3]
NOTE: Manufactured Housing may fasten at 12", 16" and 24" on center. Some use three screws on the horizontal flanges and four screws on the vertical flanges. Others utilize a perimeter-fastening strip with its own fasteners, thereby fastening and finishing at the same time.
- When other than cementitious backer board plaster is to be used, furring strips as thick as nailing flanges are recommended for installation on studs above the installed LASCO unit to assure walls will be flush. 100% silicone with mildew resistant properties should be applied between the backer board and horizontal surface of unit. Then finished wall materials can be applied. [See Diagram 4]. Refer to applicable building codes for proper finishing of other trades.
- Tub - Mounted Fittings: Refer to dimensions noted above; mark fitting locations. Using a hole saw (fine tooth or abrasive grit cutting edge), make necessary openings for filler and valves, drilling from inside (smooth side) out.
- Door Enclosures: Use LASCO shower door model for an engineered fit. Reference the Complete Works Catalog or the LASCO Bathware web-site for the shower door installation guide.
NOTE: Where local codes specify minimum door openings, shower stalls may require swing (not sliding) doors.

Clean-up

CAUTION: DO NOT USE heat, or solvent based cleaning fluids

NOTE: Do not remove adhered label. Warranty/User Maintenance Label must be left for occupant. (Required by ANSI Z124)

1. To prevent staining and/or blistering: Remove all construction debris before filling product for plumbing inspection. Drain and wipe clean immediately after the inspection process. Use sponge with warm water and liquid detergent. Do not use abrasive cleaners, such as scouring powders or pads, steel wool, scrapers, sandpapers or anything else that may scratch, mar or dull the finish. Roofing tar or paints may be removed with turpentine, rubbing alcohol or paint thinner (not lacquer thinner).
2. Plaster may be removed by scraping with the edge of a piece of wood or rigid plastic. Do not use a metal scraper or utensil to remove plaster or paint from finish.
3. Dulled areas can be restored to a high gloss with white or cream-colored automotive rubbing compound, followed by application of a coat of good quality white automotive polish (or similar) and buff with a soft cloth.
4. Remove minor scratches with 600 grit wet/dry sandpaper, followed by Step #3 (above).
5. Major gouges require professional repair.

User Maintenance Instructions

IMPORTANT! Use only recommended cleaners and procedures described herein. Use of other materials and methods may damage your bath fixture and void the warranty.

- For normal cleaning: Never use abrasive cleaners such as scouring powders or pads, steel wool, scrapers, sandpaper or anything else that could scratch or dull the surface of your LASCO unit. Instead, use warm water and liquid detergents or non-abrasive cleansers, especially those bathroom cleaners recommended for cleaning fiberglass.
- To keep your LASCO bath fixture sparkling clean: Apply a coat of good quality automotive paste wax or polish and buff to a high shine with a soft cloth or towel. Repeat every six months for easier cleaning and long lasting protection.
NOTE: DO NOT WAX textured, slip-resistant standing surface of the unit bottom. This could result in greater risk of slipping and personal injury.
- To restore a scratched or dull unit: Use an automotive polishing compound applied with a clean cotton rag. Rub scratches and dull areas vigorously. Wipe off residues. Follow with automotive wax treatment described above.
- To remove adhesive: Try 3-M Natural Cleaner, De-Solv-It or similar materials. If residues remain, saturate a small, white, cotton rag with nail polish remover (naphtha or acetone) and rub vigorously until the adhesive dissolves and disappears. These solvents are highly flammable and must be used sparingly and with caution. Do not smoke or permit others to do so. Make sure all nearby heating devices (including pilot lights) are extinguished. Do not allow solvent to go down the drain. Make sure not to contact plastic drain grates or other synthetic materials.
- Rubber Mats: If you use a rubber "anti-skid" mat, make sure to remove it from the unit after each use to avoid harm to the surface finish.
- Hard Water: Water in certain regions, if not wiped up after bathing/showering, may cause fading of some bath fixture colors. This is a natural occurrence beyond LASCO's control. (See Warranty)

CAUTION: When using any cleaning or polishing materials, make sure to read and follow all package instructions carefully. Wear rubber gloves at all times and avoid contact with eyes, skin, clothing, rugs and furnishings. Make sure all residues are rinsed off thoroughly.

Diagrams

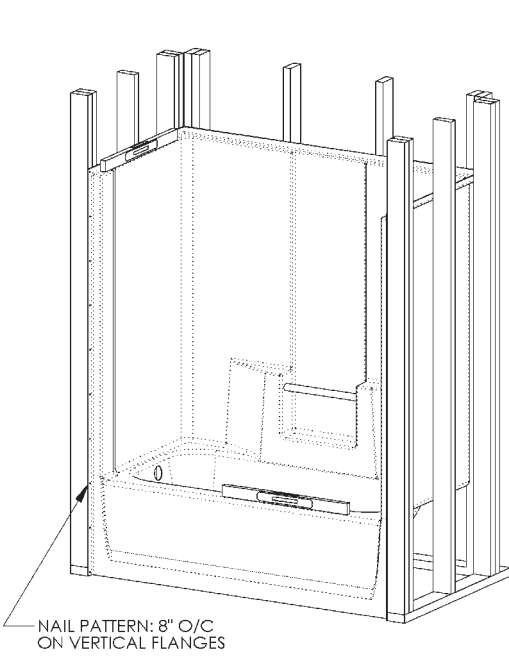
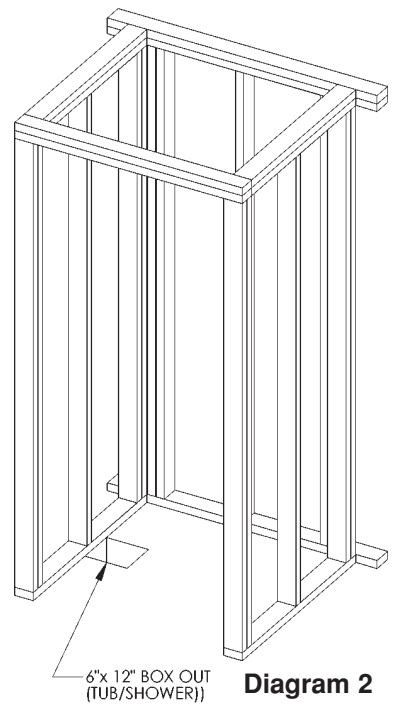
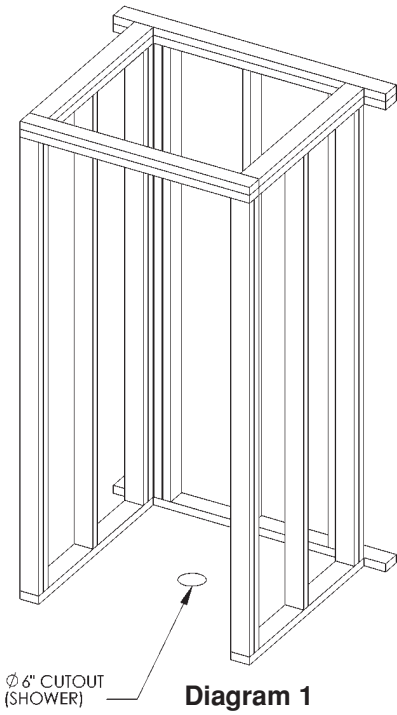
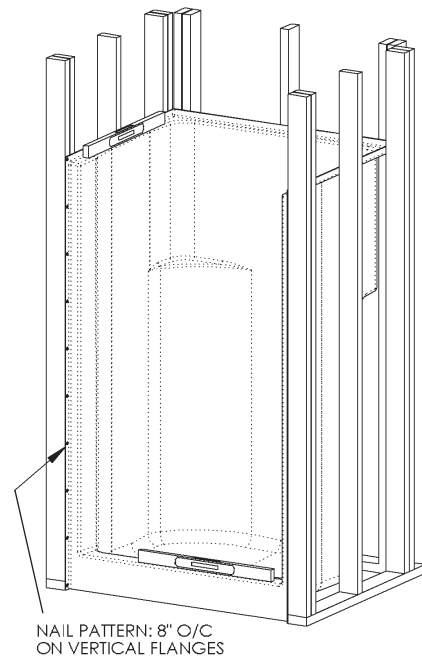

Diagram 3



Diagrams

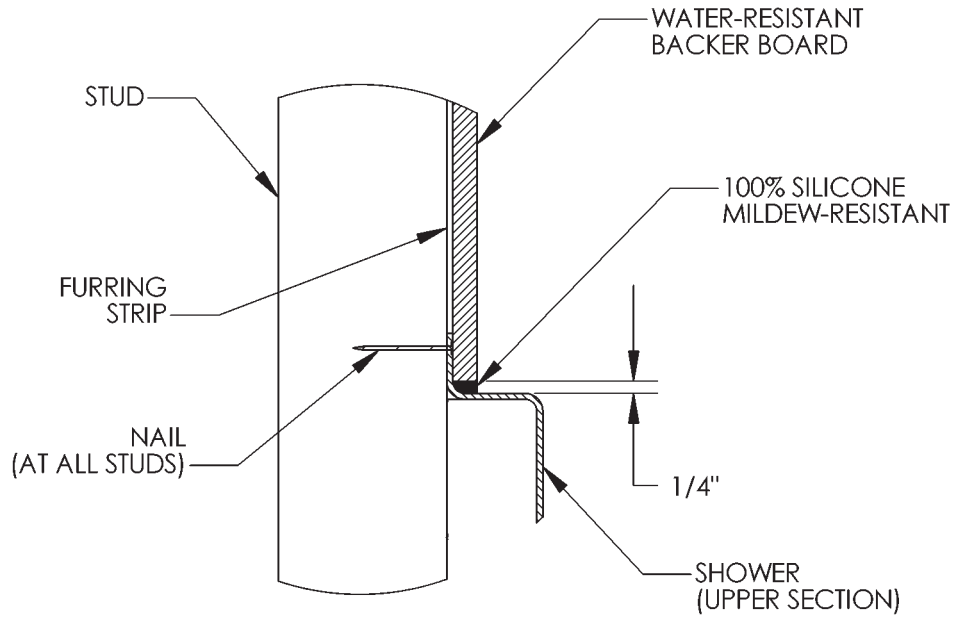

Diagram 4

Field Service/Repairs

West Central
 P.O. Box 310
 Moapa, NV 89025
 PH: 800-335-5151, 702-864-2100
 FAX: 800-799-2158

North East
 40 Industrial Road
 Conewago Industrial Park
 Elizabethtown, PA 17022
 PH: 800-444-0781
 FAX: 717-367-4722

Mid-Atlantic
 P.O. Box 1177
 Halifax County Ind'l Pk.
 So. Boston, VA 24592
 PH: 800-444-0832
 FAX: 434-572-1794

South East
 210 S. Harris St.
 Cordele, GA 31015
 PH: 800-444-0926
 FAX: 229-273-6838

North Central
 888 W. Broadway
 Three Rivers, MI 49093
 PH: 800-444-1426
 FAX: 269-273-3053

South West/South Central
 151 Industrial St.
 Lancaster, TX 75134
 PH: 800-876-3044
 FAX: 972-227-0769

West
 3261 E. Miraloma Ave.
 Anaheim, CA 92806
 PH: 800-877-0464, 714-961-9735
 FAX: 800-328-6465

Rocky Mtn./North West
 801 Northern Pacific
 Yelm, WA 98597
 PH: 800-444-5126
 FAX: 360-458-3024

Customer Service/ Sales Order

Customer Service/Sales Order
 C/O Skymark Tower
 1521 No. Cooper, Ste. 500
 Arlington, TX 76011
 PH: 800-945-2726, 817-801-8300
 FAX: 866-544-5353

Technical Services Department
 8101 E. Kaiser Blvd.
 Anaheim, CA 92808
 PH: 800-877-2005, 714-993-1220